

N°	MATIERE	A	B	Ø	R
256	NR60N	60	20	20	15
954,3	IIR70N	68	52	20	20
888	EPR65N	74	30	60	10
1326	EPR50N	130	66	104	10

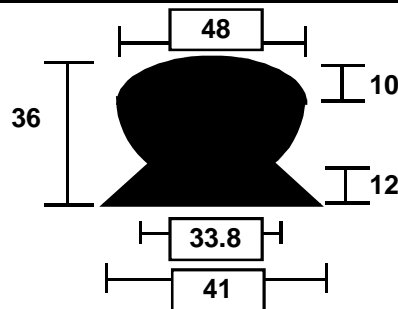

F 741 NR85 N

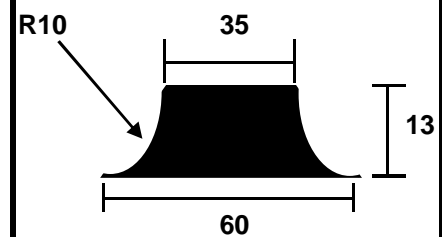

F 1235 NR 50 N

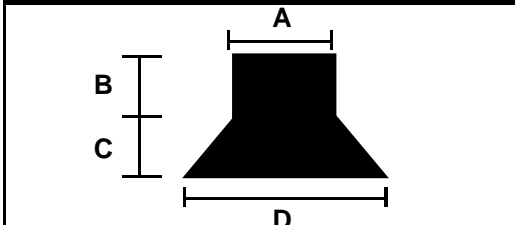

N°	MATIERE	A	B	C	D
973	FPM70N	10	10	7	13
495	NR60N	25	7	5	35

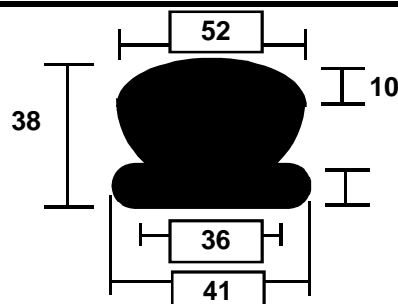

F1319 NR 75 N

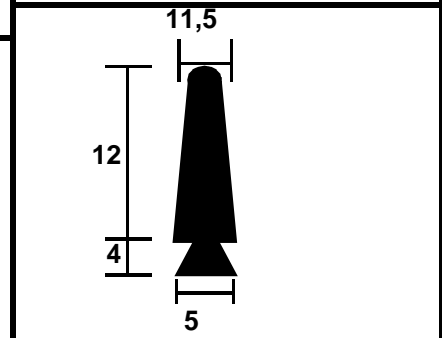

F 852 FPM 75 N

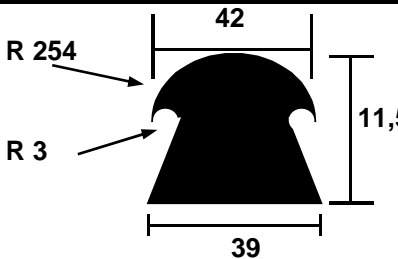

F 412 CR 70 N

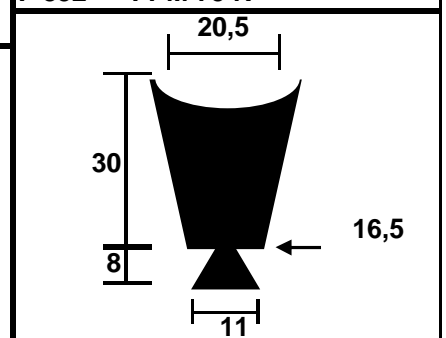

F 833 IIR 70 N

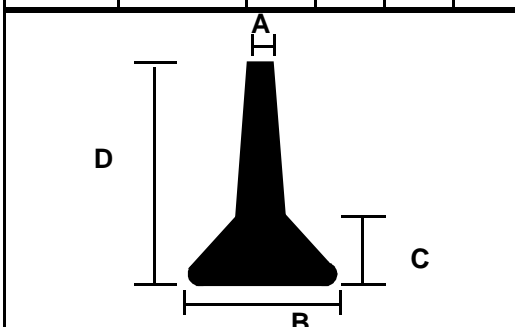

N°	MATIERE	A	B	C	D
110	NR70N	1,5	7		22
67	NR70N	3,2	7,5	2	20
182	NR70N	1	9	2,5	

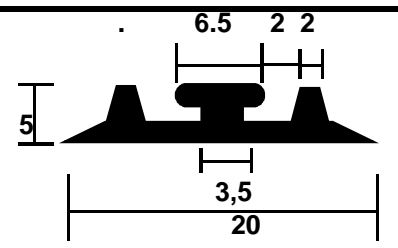

F 722 CR 65 N

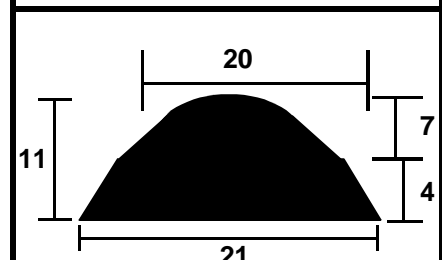

N° 381 NBR70N

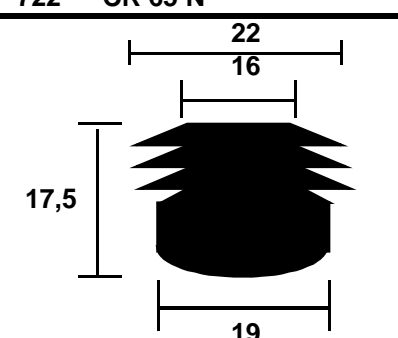

F 1074 NR60B

Attention , planche évoluant constamment . Nous consulter systématiquement